

## ODIZ Sliding Horizontal Lathe Guard Builder

Image shows standard  
16" wide guard, 25" side  
slide travel, 17" center of  
chuck to guard face  
clearance and 2" past  
centerline vertical guard  
height



# ODIZ Sliding Horizontal Lathe Guard Builder

From the products page choose Lathes then select the side sliding lathe guard.  
To build your custom fit guard simply enter the dimensions in the options tabs as defined below. You may also print lathe guard builder PDF and email the completed form to [Sales@odiz.com](mailto:Sales@odiz.com) for pricing

**Guard Width**  
( from 6" - 36" )

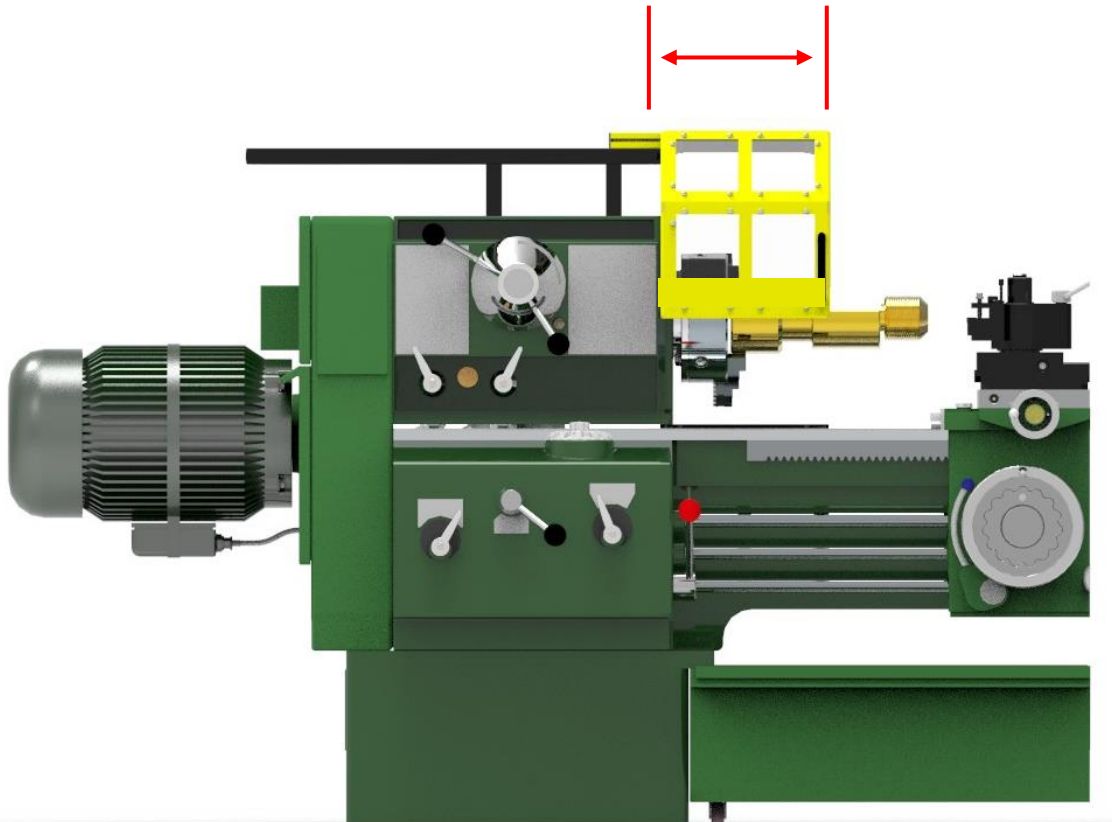

**Distance from Chuck Centerline to Clear all handles on Face of Machine 10-50" round up nearest inch**

**Distance of Guard Coverage Below Chuck Centerline Vertical 0" - 12"**

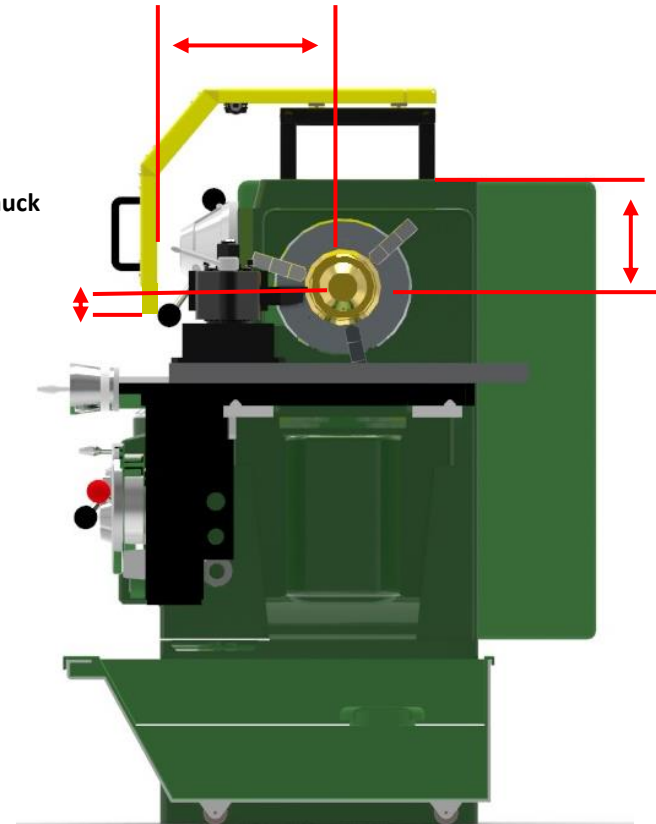

**Top of lathe to Chuck Center line 10-50 round up nearest inch**

# ODIZ Sliding Horizontal Lathe Guard Builder

From the products page choose Lathes then select the side sliding lathe guard.  
To build your custom fit guard simply enter the dimensions in the options tabs as defined below. You may also print lathe guard builder PDF and email the completed form to [Sales@odiz.com](mailto:Sales@odiz.com) for pricing

**Additional options include but are not limited to :**

Electromechanical guard position interlock switching

Automatic led lighting under guard

Custom color options

Additional handles (guards wider than 24" have two handles standard)

Inclusion of additional windows

Removal of windows

Window material ( all guards come with Lexan / polycarbonate windows standard)

Contact us for any other custom design questions

